

THE CONCEALED YET ACCESSIBLE SAFE FOR YOUR EVERYDAY VALUABLES

The EverydaySafe™

BY GUNNEBO®



INTRODUCING THE EVERYDAYSAFE	3
EVERYTHING YOU NEED TO KNOW ABOUT THE EVERYDAYSAFE	4
FEATURES & FUNCTIONS	7
FARADAY SHIELD	8
BENEFITS OF SELLING THE EVERYDAYSAFE	10
BENEFITS OF OWNING THE EVERYDAYSAFE	12
INSTALLATION	14
PACKAGING AND TRANSPORT	16
PRODUCT SPECIFICATIONS	17

Securing valuables and important belongings
in a concealed and innovative way.

Introducing the EverydaySafe

The EverydaySafe is designed to be integrated into a closet, furniture or kitchen, providing homeowners with a safe and conveniently accessible space to store their prized belongings and everyday valuables.



FAST ACCESS

Open your safe in a few seconds via the fingerprint scanner or smartphone app, allowing you to deposit or retrieve your valuables quickly and safely.



CONCEALED

Designed to be built into a range of furniture options, the EverydaySafe is hidden to everyone but you and selected users that you authorise.



SHIELDED

Faraday functionality that protects against keyless car theft (relay attacks) and contactless credit card fraud.

HIGH SECURITY

The EverydaySafe is designed to provide a high level of security and protection against the burglary of items such as passports, cash, jewellery, watches, credit cards, car keys and any other valuable or important items.





Everything you need to know about the EverydaySafe

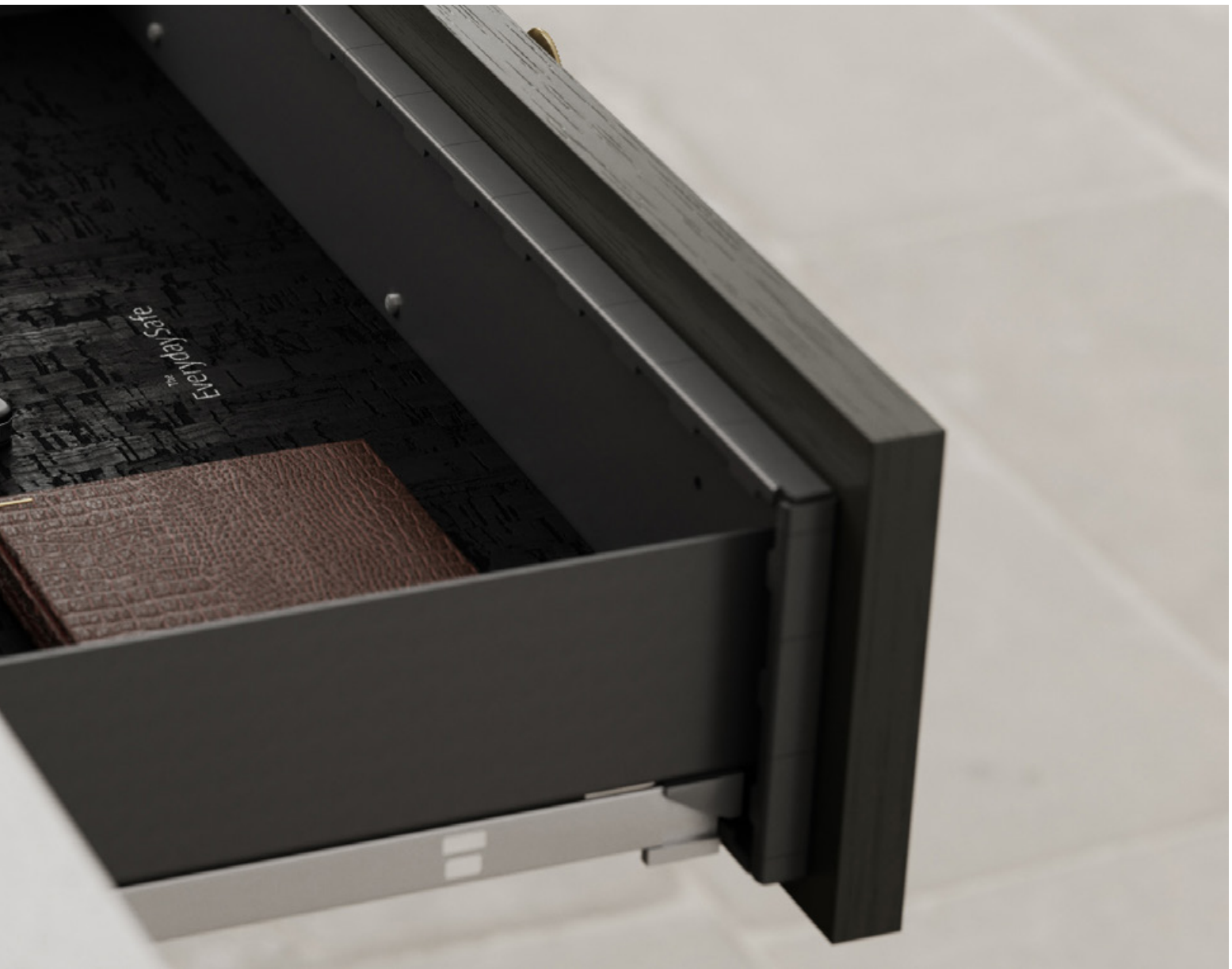

WITH AN EVERYDAYSAFE IN YOUR HOME – everything is quicker, simpler and more secure. Although the concept of a safe within a home has been around since the 13th century, it can often feel as if the safes we are presented with in the present day still hail from the same era. Safe designs are generally bulky, unattractive and cumbersome to use, and this is why they are stored away in the back of cupboards or under the stairs – rather than where we need them most.

THE EVERYDAYSAFE PROVIDES EVERYONE WITH THE OPPORTUNITY to have a sleek, innovative and digitally connected safe built discreetly into their home; providing ease of use and peace of mind. No longer do you need to concern

yourself with losing your keys or hiding your treasured watch in the sock drawer; simply come home, open your discreet safe in a matter of seconds and securely store your everyday and most valued items.

EVERYTHING ABOUT THE EVERYDAYSAFE has been designed with the customer in mind – setting out to innovate and revolutionise the way in which people store and protect their most important, valuable and treasured items in the home. This brochure has been designed to tell you everything you need to know about the EverydaySafe. For example, did you know how the EverydaySafe protects against car theft?

Certified by DEKRA

Manufacturing certifications

We list sustainability very highly on our agenda, setting high standards for our products, our employee working conditions and for the environment in which we live.

The EverydaySafe is manufactured under the most stringent of production environments in our advanced Markersdorf production facility, a factory that is ISO certified by DEKRA and demonstrates commitment to Gunnebo Sustainability Approach.



SECURITY FEATURES

- Built to an EN 14450 – S1 burglary resistance standard. **Construction tested** by Istituto Giordano, Italy **and certified** by ECB-S. Granted SS 304 Domestic Safe “Silver Level” by Sold Secure, UK.
- ECB-S class B and VDS class 2 **certified electronic high security locking unit**.
- **Software & fingerprint sensor tested** independently by Orange Cyberdefence in Malmö (Sweden)
- **Faraday functionality** that protects against keyless car theft and contactless credit card fraud.
- **Secure anchorage** protecting against any removal attempts.



INSTALLATION & OPERATION

- A **dedicated mobile app** that enables users to open and close their safe, add further users and monitor activity.
- A **biometric fingerprint solution** positioned under the safe that provides fast access in under 2 seconds.
- **Simple installation process** requiring a contractor less than 30 minutes to secure to the cabinet.
- **Great retrofit capability**, allowing you to install into an existing kitchen or piece of furniture, you just need a power source.

DESIGN & CONSTRUCTION

- Conceptualised in Sweden **and engineered in Germany**.
- Proprietary ACROBAT system (Anti-CROW-Bar-Attack) in the front which provide the **most efficient protection** against front physical attacks in its category.
- Stainless steel and **precision manufactured** locking bolts.
- **Blum Movento** runner system including soft-close function using Blumotion.
- Standard colour RAL 7016 **anthracite** with a smooth finish.



What is Faraday Shield good for?

Protect your car keys from cloning

A Faraday Cage, sometimes known as a Faraday Shield, is an enclosure that is used to shield things from electromagnetic fields, automatically blocking any wireless signals such as keyless car cloning devices, as well as wifi and mobile phone signals.



THIS IS KEY CLONING

Keyless cars unlock automatically when their key is physically close to the car. Smart criminals are using relay devices to make car systems believe a key is nearby by cloning its signal. They intercept and then relay the signal from the key using two receiver/transmitters.

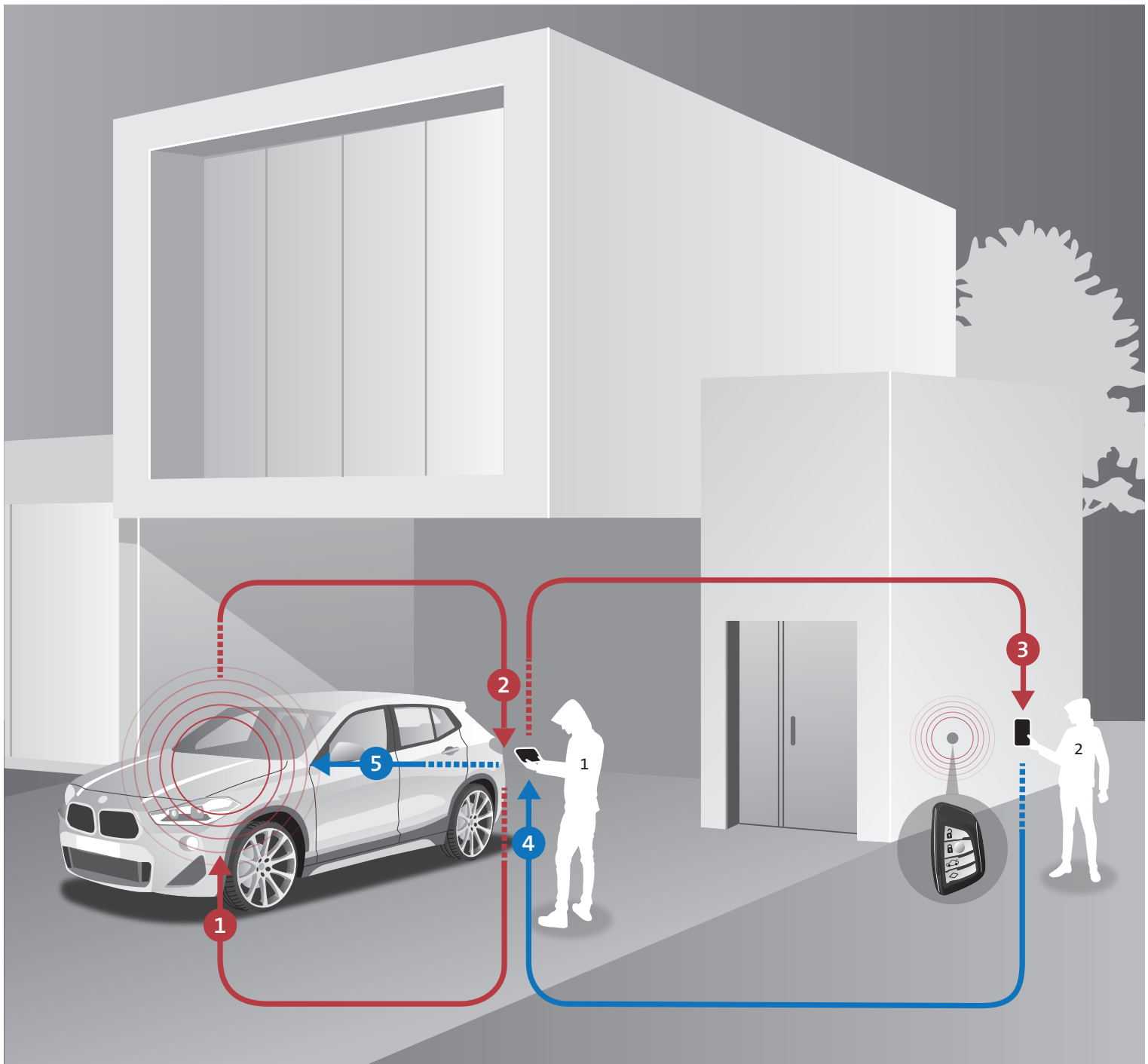

1

First thief's transmitter pings the car's locking system, impersonating the key

2

Locking system responds, sending signal that the key is meant to pick up and respond to

3

First thief's transmitter forwards the signal to the other thief near the house

4

His transmitter sends it on to the key fob and then relays back the 'correct' response from the key fob to the first thief's transmitter

5

This signal is then routed to the car's locking system, opens the car and starts the ignition



ENGINEERED IN GERMANY



ENGINEERED IN GERMANY using the Blum Movento and Blumotion system, the EverydaySafe provides you with a unique opportunity to design a home that offers your customers a concealed and convenient space to store their prized belongings and everyday valuables.

Benefits of selling the EverydaySafe

ADDITIONAL REVENUE STREAM

EverydaySafe provides an additional source of income that complements rather than competes with the other products you offer

DIFFERENTIATE YOURSELF FROM THE COMPETITION

Selling the EverydaySafe you can stand out against your competition when competing to win costumers

RE-ENGAGE WITH PREVIOUS CLIENTS

The EverydaySafe can be retrofitted into a cabinet or furniture, giving you the ideal opportunity to reconnect and sell to prior customers

INCORPORATE INTO ANY DESIGN

The EverydaySafe is available in a variety of file formats including DWG | BIM Object | DXF | RVT | 3DS and SketchUp to ensure you can easily add it to your design software

INTEGRATES WITH ANY DRAWER SYSTEM

The EverydaySafe drawer in a drawer option can be fitted within any Blum, Hettich, Grass or Matrix by Hafele drawer system

STANDARDIZED MEASUREMENTS

The EverydaySafe single drawer design fits a standard 600mm cabinet, offering the flexibility to attach any manufacturers drawer front to the front of the safe so it matches the rest of the cabinet

EASY INSTALLATION

The EverydaySafe takes less than 30 minutes to install and comes with a simple to follow installation guide

CUSTOMER & PRODUCT SUPPORT

The Support Team is always on hand to help with any product, installation or logistic queries

The Why's and What's

Benefits of owning the EverydaySafe

We analysed the residential safe market and understood there had been a lack of innovation, imagination and development for a number of years. Current safes weren't suited to peoples' modern lives and needs. Changing threats meant we had to step up our game.

Therefore the EverydaySafe has been designed with the customer in mind. This customer-centric approach led us to develop a solution that compliments a users daily life.



THEFT AND THIEVES

Independent of current statistics, burglaries will always happen. Let us help you minimise the potential fall-out. You can reduce the likelihood that your valuables will be stolen by securing them in an entirely concealed EverydaySafe. Protect your loved ones, precious items and cars.

WHY HOMEOWNERS NEED AN EVERYDAYSAFE

- Delivers fast, convenient, digital access to a safe
- Hidden and concealed for maximum protection
- Multi-layered security to safeguard against burglary and car theft
- Undetectable unless activated by a user
- Secure storage solution that fits their daily routine
- Convenient installation with minimal disruption
- Does not alter the style or appearance of the home
- 2-year product guarantee
- Meets Insurance standards for £20K valuables and £2K cash

WHAT HOMEOWNERS CAN DO WITH AN EVERYDAYSAFE

- Store everyday necessities such as car keys, wallets and watches
- Hide valuable and treasured items, protecting them against theft or damage
- Stop family members from accessing emergency medicine e.g. Epi-Pen
- Securely lock keys to a gun cabinet
- Restrict children's usage of electronic devices
- Easily access passport for business trips
- Safely store watches, rings etc during home improvement projects
- Add additional users, such as their partner or other family members
- Monitor safe usage – who has opened it and when



A process designed for simplicity

Installation

The EverydaySafe has been designed to ensure a fast, simple and mess-free installation process. It has been engineered for simple installation in under 30 minutes – with the flexibility to be included in a single drawer, or drawer in drawer solution.

We understand that you may want to dig into the finer technical details for the EverydaySafe. With this in mind, we have produced an extensive and exhaustive technical manual to provide you with this level of information.



MORE INFORMATION ABOUT THE INSTALLATION IS AVAILABLE IN THE USER GUIDE AND ON OUR WEBSITE WWW.EVERYDAYSAFE.COM

STANDARDIZED MEASUREMENTS

The EverydaySafe is designed to fit into any standard 600mm cabinet, and accommodates 16 mm – 22 mm carcasses.

The weight of the case is 19.5 kg and the drawer 7 kg.

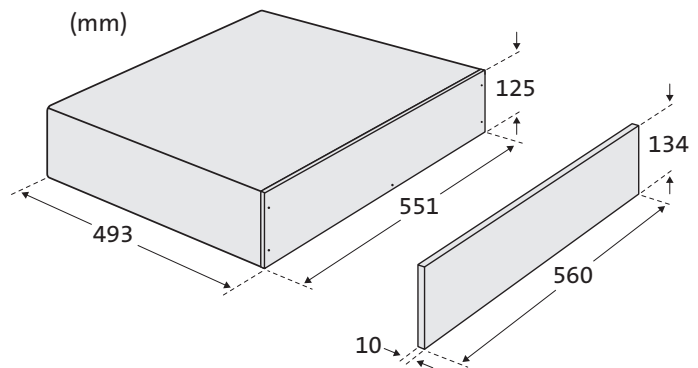

INSTALLATION OPTIONS

PROVIDING FLEXIBILITY FOR YOU AND YOUR CUSTOMERS VIA TWO INSTALLATION OPTIONS – DRAWER IN DRAWER AND SINGLE DRAWER.

Recognising the variety of styles and configurations of individual designs, we have set about to ensure that installing the EverydaySafe is as accommodating as possible, for both resellers and customers.

With this in mind, the EverydaySafe solution and accompanying Blum Movento runner system is able to be installed in either a drawer in drawer or single drawer. Please see the full installation guide for more details on how this is specifically achieved.

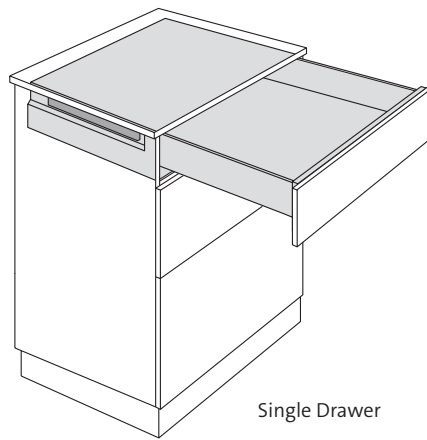
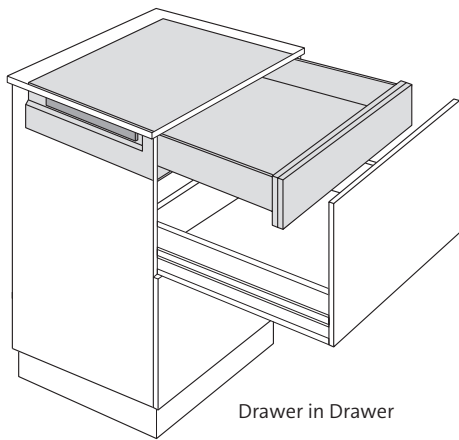

Packaging and transport

Presentation and professionalism are two values that permeate the EverydaySafe, from the work put in on our factory floor to the moment it arrives at a customer's property. We ensure that all EverydaySafe's arrive clearly marked and identifiable due the high quality packaging stickers – and we have outlined a few further guidelines to ensure this premium feel is evident from the moment customer's take delivery.

TO ENSURE THE SAFE TRANSPORTATION AND ARRIVAL OF EVERYDAYSAFE, PLEASE TAKE NOTE OF THE FOLLOWING:

- This is a high performance safe, as such it's heavy and **should be secured during transport**
- Please be aware that items – such as other appliances – should **not be stored or placed on top** of the EverydaySafe
- Overall **packaging dimensions** are W 600 × D 550 × H 200 mm
- The **total weight** per package is 46 kg



WE ARE HERE TO HELP. REACH OUT TO US VIA OUR SUPPORT CHANNELS

Email: support.everydaysafe@gunnebo.com Phone: +44 1902 904030

Specifications

Global article code: P000022619

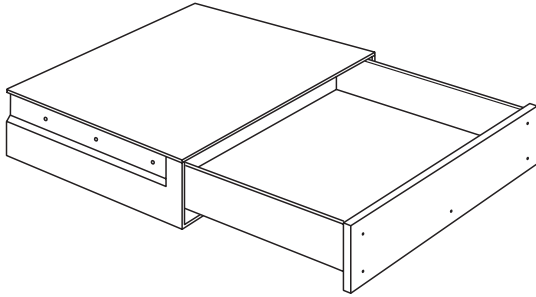

MAIN FEATURES

App connectivity & user management

The EverydaySafe app is available for iOS and Android

Protection

Burglary resistance – built to a certified EN 14450 construction – S1 level, Faraday; S5 304 Domestic Safe Sold Secure Silver level

Country of origin

Made in EU

Installation width

Easy mounting into a width of 556 to 568 mm wide cabinets

Operation

Simple, fast yet safe access by means of fingerprint sensor

Colour

Standard colour RAL 7016 anthracite

Standard inlay

Premium cork mat

PHYSICAL PROPERTIES

Overall packaging dimensions (WxDxH)

600 x 550 x 200 mm

Case dimensions (WxDxH)

551 x 493 x 125 mm

Wooden front dimensions (WxDxH)

560 x 10 x 140 mm

Drawer inner dimensions (WxDxH)

500 x 441 x 68 mm

Inner volume

15 litres

Case weight

19.5 kg

Drawer weight

7 kg

Signature feature

ACROBAT system (patent pending)

Maximum weight storage

20 kg

MECHANICAL PROPERTIES & FUNCTIONALITY

Soft close function

Yes (Blumotion)

Automatic lock when closing

Yes

Durability testing

over 25,000 life cycles (opening & closing)

Time to open

under 5 seconds

Runner System

Yes (Blum Movento)
Soft close function

ELECTRONICAL COMPONENTS & CONNECTIONS

Power lead to mains

230V/ 12V, 1.2m cord length, connected at bottom rear of case

Power plug

EU or UK

Fingerprint sensor

Capacitive sensor; IPx7

In the event of a power cut

9v battery can be connected for short time use at bottom of case by user, data is not erased

Reset function

Via app

SECURITY FEATURES

Safety standards

built to a EN 14450 – S1 standard; Sold Secure Silver level

Front protection

New proprietary ACROBAT system (Anti-CROW-Bar-ATtack) in the front which provide the most efficient protection against front physical attacks in its category

Locks

Prime locks certified to ECB-S Class B and VDS Class 2

Faraday protection

protection against data theft at a distance > 10cm

Code and key encryption

storage in a safe hardware unit (HSM)

Software & fingerprint sensor testing

Orange Cyberdefence in Malmö (Sweden)

Fire protection

No

APP FUNCTIONS & FEATURES

Connectivity

Wi-Fi and Bluetooth

Users per safe

1 app user per safe, up to 20 fingerprint users per safe

Users administration & monitoring

Yes, via the EverydaySafe app

Factory default settings

Free opening by any fingerprint

Activity log

12 months activity log

INSTALLATION OPTIONS

Single drawer undercounter

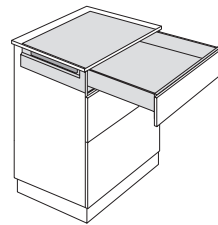

Drawer-in-drawer

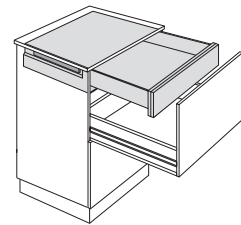

The mounted wooden front is supposed to be flush-fitted with the cabinet. We do not recommend to install The EverydaySafe in direct or close access to a source of heat or water.

INSTALLATION STEPS

Unpacking

without turning box upside down, extract from the box, cutting the corners if needed

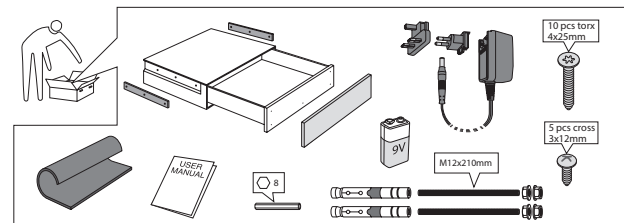

Preparing

place appliance on flat surface and extract drawer from case (2 people needed)

Drilling and anchoring to wall

via two M12 210 mm adjustable fixing bolts, once the case has been pushed onto the supports

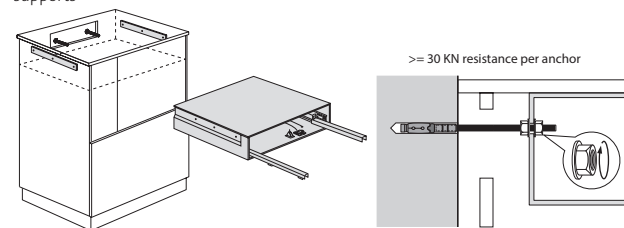

Connecting

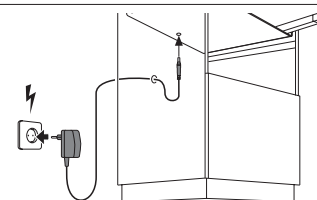



LEARN MORE HERE

Scan this QR code with your smartphone
or visit www.everydaysafe.com

The
EverydaySafe™

BY **GUNNEBO**®